

TECHNOLOGY DEVELOPMENT FOR LUNAR BASE WATER RECYCLING N 9 3 - 1 3 9 9 9

John R. Schultz

*KRUG International
1290 Hercules, Suite 120
Houston TX 77058*

Richard L. Sauer

*Mail Code SD 411
NASA Johnson Space Center
Houston TX 77058*

INTRODUCTION

The establishment of a lunar base is being considered as one of the long-term goals of the U.S. Space Program. The proposed functions of such a facility include scientific research, exploitation of lunar resources, and development of a self-sufficient life support system. *Duke et al.* (1985) have discussed a phased approach for developing a lunar base. The first step would be the establishment of a lunar orbiting space station for preparatory exploration. The second phase would be the establishment of a small lunar surface research outpost based on space station technology. The next phase would be the development of an operational base for pilot-plant work on lunar agriculture and lunar material utilization. An advanced base would then follow that would emphasize oxygen production from lunar resources and research on closed ecological life support systems (CELSS). The final phase would be the development of a self-sufficient colony with an operational CELSS and full-scale oxygen production from lunar resources.

The development of a lunar base will require the development of processes to produce and recycle oxygen, food, and water. Closure of the life support system is necessary to reduce resupply requirements and associated costs as much as possible. The requirements for such a system have been outlined and discussed in several previous papers (*MacElroy et al.*, 1985; *Sauer*, 1985; *Spurlock and Modell*, 1979; *Spurlock et al.*, 1979). Since water is essential for maintaining life, the ability to recycle water will play an important role in maintaining a lunar base. Unfortunately, direct recycling of water for drinking is presently not performed to any great extent in terrestrial systems. In addition, many of the processes commonly used for water reclamation and purification on Earth may not be suitable for aerospace application because they are highly gravity dependent and require chemicals that need to be resupplied. NASA has recognized this problem and supported numerous research efforts aimed at developing water reclamation technology for aerospace applications. This paper will review previous and ongoing work in aerospace water recycling and identify research activities required to support development of a lunar base.

DISTILLATION PROCESSES

Much of NASA's water recycling research effort has focused on the development of distillation processes. Unfortunately, the processes commonly used on Earth are highly gravity dependent and need modifications for use in microgravity conditions. Processes currently under development to overcome this problem include vapor compression distillation, thermoelectric integrated membrane evaporation, and wick evaporation.

Vapor Compression Distillation

One process being developed to reclaim water from urine is vapor compression distillation (VCD). This process consists of a rotating still that recovers water by evaporation at subatmospheric pressure followed by compression and condensation of the resulting water vapor (*Zdankiewicz and Chu*, 1986). To reduce heat requirements, the process is arranged so that the heat flux from the condenser is used to evaporate the water. This results in a process with high water recoveries and low power consumption. Unfortunately, the recovered water does not meet NASA potable water standards for ammonia and volatile organics without additional pre- and post-treatment processes (*Slavin et al.*, 1986).

TIMES

The thermoelectric integrated membrane evaporation system (TIMES) is being developed by Hamilton Standard (*Debner and Price*, 1987). In this process, water is passed through a hollow fiber membrane device at subatmospheric pressure. The water to be recovered diffuses through the membrane as a vapor. The water vapor is then recovered with a porous plate condenser. A thermoelectric device is used to recover the latent heat of condensation. Similar to the VCD process, this process has high water recoveries and low power consumption; however, it cannot process solids and also has problems with ammonia and volatile organics (*Slavin et al.*, 1986).

Wick Evaporation System

Another system being developed is the wick evaporation system (Hall, 1973). In this process, water is fed into an assembly consisting of a series of rayon felt wicks. The water is then evaporated by a heated air stream that passes through the wicks leaving the contaminants behind. The water vapor is then recovered with a condenser and a centrifugal air-water separator. This process has been used in previous 60- and 90-day manned chamber tests conducted by *McDonnell Douglas* (1968, 1970) in the late 1960s and the early 1970s. This process also requires the use of pre- and post-treatment processes to meet water quality standards. Current work with this process is aimed at simplifying operation and reducing energy requirements (*Morasko et al.*, 1986).

VPCAR

The vapor phase catalytic ammonia removal system (VPCAR) was developed to overcome the problems that ammonia and volatile organics carry over from distillation processes (*Budininkas et al.*, 1986). This process consists of a hollow fiber membrane evaporator followed by two catalytic reactors to convert ammonia to nitrogen and volatile organics to carbon dioxide. After passage through the reactors, the water vapor is recovered with a condenser. Unfortunately, this process is not capable of handling solids and has higher cost, volume, and power requirements than the VCD or TIMES processes.

The above processes are more complex and costly than terrestrial systems because of the requirement to work under microgravity conditions. Fortunately, this requirement will not be necessary for a lunar base application. The $\frac{1}{6}g$ at the lunar surface should allow development of an air-liquid interface and may allow simpler and less costly terrestrial distillation processes to be used. The problems with low removals of ammonia and volatile organics, however, will still remain. Thus, research on developing and evaluating distillation systems that operate under lunar surface conditions needs to be initiated.

MEMBRANE PROCESSES

The phase-change processes described above are primarily being developed to treat highly contaminated wastewaters such as urine. Because of their high energy requirements, these processes are thought to be nonoptimal for treating shower, personal hygiene, and housekeeping wash waters. Since these wash waters may contain low concentrations of high-molecular-weight compounds, the use of membrane processes is considered a viable alternative. The two membrane processes that appear most suitable for aerospace applications are reverse osmosis (RO) and ultrafiltration (UF). Ultrafiltration is mainly a filtration process that rejects suspended solids and macromolecules but allows low-molecular-weight salts to pass through the membrane. Reverse osmosis, however, rejects all suspended solids, macromolecules, and most of the low-molecular-weight salts.

Studies by Bend Research (*Ray et al.*, 1986) indicate that a two-stage RO system could be successfully used to treat a synthetic wash water. Further development work has emphasized the use of UF processes as a pretreatment for RO (*McCray et al.*, 1987). A study on using RO to recover actual shower water has also been conducted (*Verostko et al.*, 1987). The results indicate that an RO process followed by multifiltration posttreatment was able to provide water acceptable for hygiene use.

With respect to lunar base applications, the disadvantages of membrane systems include the production of a waste brine solution and the need to periodically replace the membranes. The waste brines are produced because membrane processes are normally operated in a cross-flow mode to minimize fouling. The problem with the waste brine may be reduced by increasing water recoveries or by processing the brines with a combustion process as discussed later.

PRETREATMENT PROCESSES

A major problem with most of the phase-change processes discussed above is their inability to remove ammonia and volatile organics. Various pretreatment chemicals have been investigated to overcome this problem. The addition of sulfuric acid and oxone has been used to fix free ammonia in shower water and prevent its carry-over in TIMES distillate (*Verostko et al.*, 1986). Unfortunately, the use of oxone has been shown to produce more volatile organics in urine distillate (*Putnam et al.*, 1986). In this case, better results have been obtained with nonoxidizing chemicals such as hexadecyl trimethyl ammonium bromide (HDAB) or a copper/chromium metal mixture. With respect to a lunar base, the use of pretreatment chemicals will require that they be periodically resupplied from Earth. This will make their use undesirable at a lunar base. Thus, research on developing alternate pretreatment processes such as biological, chemical, or electrochemical oxidation needs to be initiated.

MULTIFILTRATION

The most commonly used process for polishing product water from distillation and membrane processes is multifiltration. Multifiltration consists of a train of sorption beds containing various ion exchange, activated carbon, and polymeric resins in series. This system has been shown to be effective for polishing both distillation and RO product waters (*Verostko et al.*, 1986, 1987). Unfortunately, the resins have a finite lifetime and need to be periodically replaced as they are exhausted. Current work is emphasizing the development of a unibed consisting of a single canister containing the various sorbents packed in series. This approach is aimed at eliminating the requirement for maintaining a large inventory of spare resins for changeout.

With respect to a lunar base, the need to replace the sorbent beds presents some problems. A completely self-sufficient base will require the development of methods to regenerate the sorbents. Ion exchange resins can be regenerated with strong acid or base solutions. Activated carbon is usually regenerated with a high-temperature furnace. Research developing and evaluating these techniques for lunar base use is needed. The use of alternate processes for polishing the water also needs to be investigated.

DISINFECTION PROCESSES

Microbial contamination is a major concern with terrestrial water systems. Water treatment processes such as filters, carbon adsorption beds, and ion exchange resins can encourage microbial contamination of the system by nutrient enrichment. Furthermore, virtually all system surfaces in contact with the water may become colonized by biofilm formation. Thus, water supply systems can be a source of disease if the water is not properly treated and the system properly maintained.

Microbial control is usually accomplished by the addition of chemicals to disinfect the water. Although chlorine is commonly

used in terrestrial systems, it is not currently being used in the space shuttle potable water system (Willis and Schultz, 1987). Instead, iodine is used because it has a lower vapor pressure than chlorine and can be easily added with an iodinated ion exchange resin called a microbial check valve (Columbo *et al.*, 1981). The use of iodine, however, is not without problems. The long-term health effects of ingestion of iodinated water are unknown (Bull, 1987). Iodine may react with trace organics to form halogenated organics, which have been implicated in cancer formation (Janik *et al.*, 1987). Various bacteria have been shown to develop a resistance to iodine action (McFeters and Pyle, 1987). Finally, iodine may impart an unpleasant taste to the water (Willis and Schultz, 1987).

Another disinfection technique that has been investigated for aerospace applications is heat. During manned chamber tests conducted in the late 1960s, disinfection was accomplished by holding water at 72°C for 6 hr (McDonnell Douglas, 1968). Temperature "spiking" has also been used for controlling microbial growth in RO systems (Ray *et al.*, 1986). The advantages of using heat are its applicability to all types of organisms, its sensitivity to chemical interferences, its effectiveness in the presence of particulates and biofilms, and its nondependence on expendable materials. The disadvantages, however, include high energy requirements and the lack of applicability to cold water (Columbo and Sauer, 1987).

Ultraviolet irradiation has also been evaluated in several studies (Hall, 1973; Putnam *et al.*, 1986). Although this method has been successful in reducing bacterial counts, it does not leave a residual disinfectant for controlling growth in the distribution system and must be used with other disinfectants. It also has higher power requirements than chemical addition methods such as iodine (Columbo and Sauer, 1987).

The use of ozone in terrestrial water systems has been steadily increasing over the past decade. Its possible use on the space station has not been pursued because of the need to develop microgravity gas-liquid contacting and separation processes, the high energy associated with its formation, and its potential for causing an offgas problem. The microgravity compatibility problem, however, will be reduced in the lunar environment.

With respect to lunar base application, a major problem with chemical disinfectants such as iodine will be the need to periodically resupply the chemical. Thus, a research program aimed at developing iodine recovery methods and alternate disinfectants is needed. The health effects due to possible buildup of iodide and iodinated by-products also needs to be evaluated. To reduce the potential for developing iodine-resistant bacteria, the use of at least two disinfection methods has been recommended (Willis and Bull, 1987). The development of point-of-use deiodinators to reduce taste and potential health problems also needs to be explored.

COMBUSTION PROCESSES

The phase-change processes being developed for the space station are mainly aimed at recovering water from liquid wastes only. To close the recycle loop and reduce resupply requirements, it will be necessary to also process solid wastes. Candidate processes that have been examined to accomplish this include incineration, wet oxidation, and supercritical water oxidation.

Incineration

The use of incineration has been evaluated by both GARD and GE in the early 1970s (Slavin *et al.*, 1986; Murray and Sauer,

1986). Both efforts resulted in the development of prototype units that were subjected to long-term tests. These systems require pre-concentration of solids. They also produce very dirty effluent gas streams requiring posttreatment by catalytic oxidation. Successful use of these systems will require further development with respect to microgravity compatibility and automatic operation.

Wet Oxidation

A wet oxidation process was evaluated by Lockheed in the early 1970s (Slavin *et al.*, 1986). This process involves the oxidation of both liquid and solid wastes at elevated temperatures (550°F) and pressure (2000 psia). Its advantages include the ability to handle liquid wastes without preconcentration, automatic operation, and the production of a sterile effluent. Disadvantages of this process include its high temperature and pressure operation and the production of a relatively dirty effluent stream requiring extensive posttreatment.

Supercritical Wet Oxidation

This process being developed by Modar involves the oxidation of aqueous wastes at a temperature of 250°C and a pressure of 250 atm. At these conditions, inorganic salts that are soluble in water are insoluble and will precipitate from solution (Hall and Brewer, 1986). Primary results show that aqueous solutions of urea and sodium chloride can be effectively treated with essentially complete conversion of carbon to CO₂ and nitrogen to N₂ and N₂O (Hong *et al.*, 1987). Its disadvantages include relatively high weight, volume, and power requirements due to its high operating temperature and pressure.

BIOLOGICAL PROCESSES

Biological processes are commonly used in terrestrial wastewater reclamation systems because they are more efficient than physical or chemical processes. Unfortunately, these processes are very gravity dependent and major development work will be required to make them zero-g compatible. These processes also have slow response times, which can cause problems if they malfunction; thus, biological processes are presently perceived as too unreliable for the space station life support system, and very little development work has been done in the past. A lunar base, however, will be in a 1/6-g environment, and the application of terrestrial biological processes might be feasible. To insure that adequate technology is available for lunar base development, evaluation of such processes needs to be initiated. Particular attention needs to be aimed at both carbon and ammonia oxidation processes using fixed film configurations.

NUTRIENT RECOVERY PROCESSES

The operation of plant growth systems at a lunar base will require the addition of nutrients such as nitrogen, phosphorus, and other minerals. Initial systems will probably use stored nutrient solutions that will have to be resupplied. To reduce these resupply requirements, the recovery and recycling of various nutrients is highly desirable. Very little work has been done on developing such systems. Meissner and Model (1979) have discussed processing schemes for removing sodium chloride from ash produced by total oxidation systems. One potential source for recovering these nutrients will be the various wastewater streams. Another possible method for recycling nutrients is the direct

application of wastewater to the plant system. Although this has been done in terrestrial systems, lunar base applications may require some development because of the reduced gravity, different soil, and more concentrated waste streams. A third method would be the separate recovery of nutrients such as ammonia and phosphates using ion exchange processes. This would also require considerable development work.

WATER QUALITY MONITORING

Total Organic Carbon

Another area that will need a major development effort is instrumentation to monitor and control water quality. Many of the instruments presently used in terrestrial laboratories are very gravity dependent and will require extensive modification for in-flight use. Several concepts have been explored for monitoring total organic carbon (TOC) in water, including ultraviolet absorbance, high-temperature combustion, and chemical oxidation (Small, 1987). The persulfate oxidation method has the capability of measuring organics at the 10 ppb level, but, unfortunately, requires a sparging vessel that is not microgravity compatible (Modar, 1984).

Specific Organics

Measurement of total organic carbon does not guarantee a water is safe to use. The identification and quantification of specific organics is also needed because ingestion of trace amounts of some organics can be hazardous. Zlatkis (1986) has reviewed the state of the art for measuring specific organics and proposed the use of a gas chromatograph system with either a photoionization or far ultraviolet detector. A purge-and-trap device would be used to concentrate and inject the organics into the gas chromatograph. Unfortunately, the microgravity incompatibility of present purge-and-trap methods was not discussed. Another problem with a gas chromatography system is that it may only be capable of accounting for 10% to 30% of the organics in reclaimed water (Verostko *et al.*, 1986, 1987).

Specific Inorganics

Inorganic compounds include many essential nutrients and trace metals. Some of these compounds can be hazardous at concentrations lower than would be detected by conductivity measurements. The state-of-the-art method for measuring trace amounts of metals is atomic absorption spectrometry. Unfortunately, this method has large power and expendable requirements. Also, it is not capable of measuring many of the common anions. Alternative methods that may be used for measuring specific inorganics include ion chromatography and ion selective electrodes. Ion chromatography is capable of measuring many common anions, cations, and trace metals, but requires the use of expendable solvents.

Microbial Contaminants

In order to verify the microbial quality of the recycled water, it will be necessary to develop methods for in-flight sampling and enumeration of contaminating bacteria. Present methods for enumerating bacteria in terrestrial water systems include membrane filter and plate count techniques. The major disadvantage of these methods is the requirement for several days of incubation prior to counting. A faster method being investigated is epifluorescence microscopy (Pierson and Brown, 1987). Regardless of the enu-

meration technique, a capability for in-flight identification of the bacteria must exist to support decisions on the potability of the water in the event of contamination. Automated biochemical methods are presently being developed to accomplish this task (Pierson and Brown, 1987). Although this technology appears to be promising, its applicability for detecting pathogens in water still needs to be demonstrated.

INTEGRATED SYSTEMS

Manned Chamber Tests

The feasibility of using a regenerative life support system based on physical and chemical processes has been demonstrated in 60- and 90-day manned chamber tests conducted by McDonnell Douglas in 1968 and 1970, respectively (McDonnell Douglas, 1968, 1970). As shown in Fig. 1, potable water was reclaimed from both urine and humidity condensate. The recovery system consisted of a wick evaporator process followed by a multifiltration system. Disinfection of the potable water was accomplished by heating, membrane filtration, and silver addition. This system produced water suitable for crew consumption in 57 out of 60 days during the 60-day test and throughout the 90-day test. Wash water was recovered by using a multifiltration system as shown in Fig. 2. Microbial control consisted of ultraviolet irradiation before the multifiltration unit and heating of the product water. Microbial analyses conducted during the 60-day test indicated this system could not maintain sterility of the recovered water. The use of the contaminated water, however, did not produce any adverse effects.

Space Station ECLSS

The present plans for the space station Environmental Control and Life Support System (ECLSS) are shown in Fig. 3 (Ray and Humphries, 1986). Humidity condensate will serve as the source of potable water. Urine and wash water will serve as the source of hygiene water. Fecal matter is presently not considered a practical water source because of the small amount of water in feces and the relative difficulty in reclaiming this water. Separate recovery systems will be developed for each source of water. The exact processes to be used in each subsystem have still not been specified but will consist of physical or chemical processes. Subsystem configurations presently being considered are shown in Fig. 4. Although testing of several of the processes and subsystems has been conducted, integrated testing of the overall system has yet to be completed. Such tests are presently planned for the early 1990s (Moses *et al.*, 1987).

Integrated Waste and Water Management System

The initial space station ECLSS will not process feces and other solid wastes. During the early 1970s, GE developed a system capable of handling such wastes called the Integrated Waste and Water Management System (IWWMS) (Murray and Sauer, 1986). As shown in Fig. 5, this system consists of evaporation followed by catalytic oxidation to recover potable water. The dried solids were then incinerated to produce a sterile ash. This system was successfully operated for 206 days using a 4-man equivalent of urine, feces, wash water, condensate, and trash. The prototype system has been recently donated to Texas A&M University, which plans to resume development of the system.

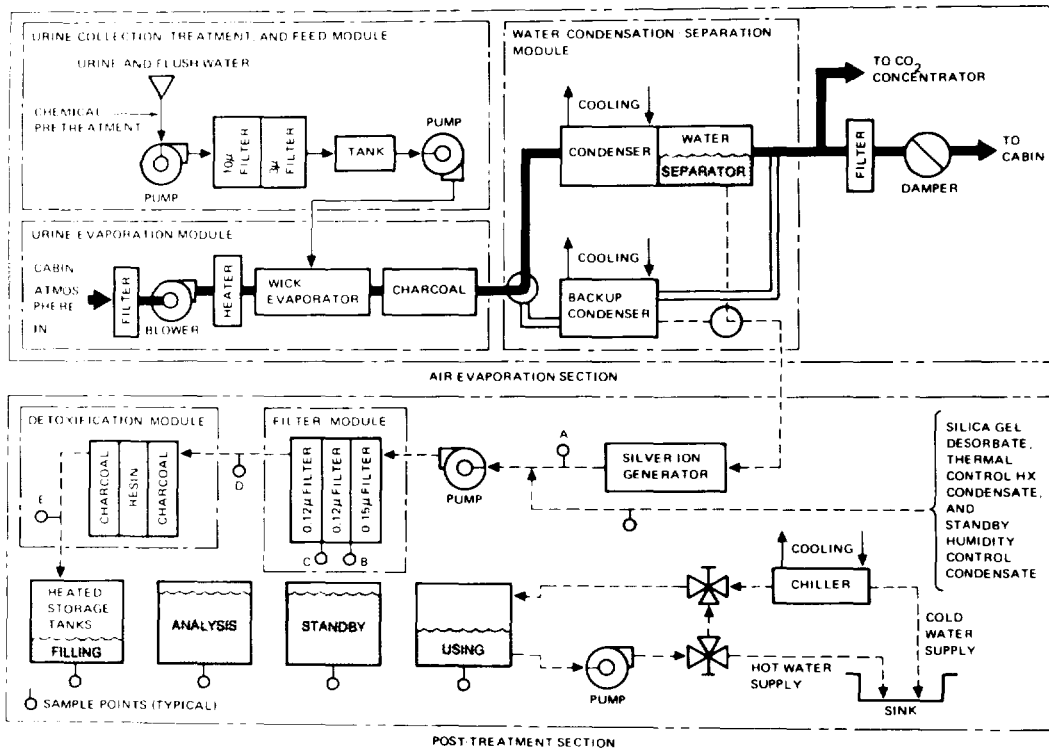

Fig. 1. Potable water recovery subsystem used in McDonnell Douglas tests.

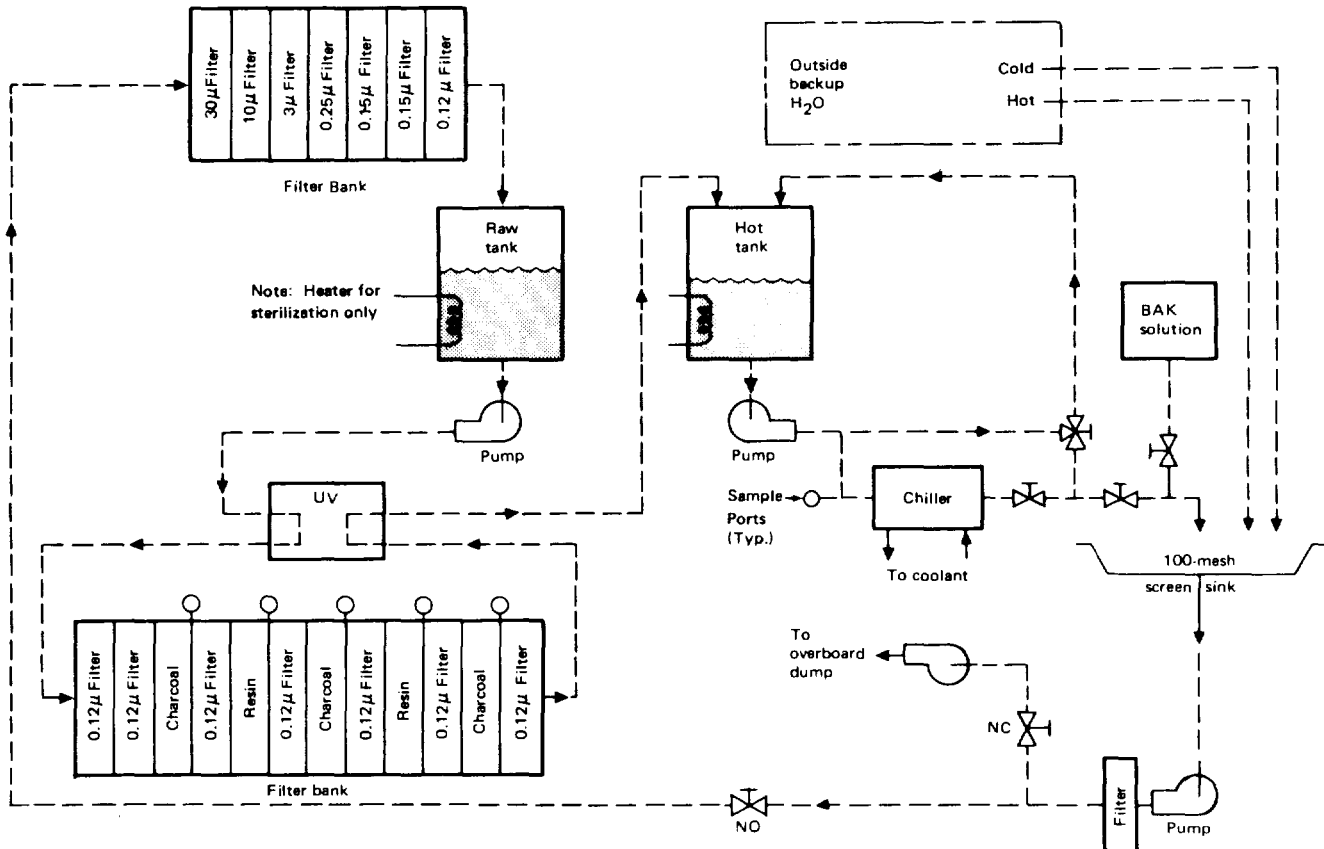

Fig. 2. Wash water recovery subsystem used in McDonnell Douglas tests.

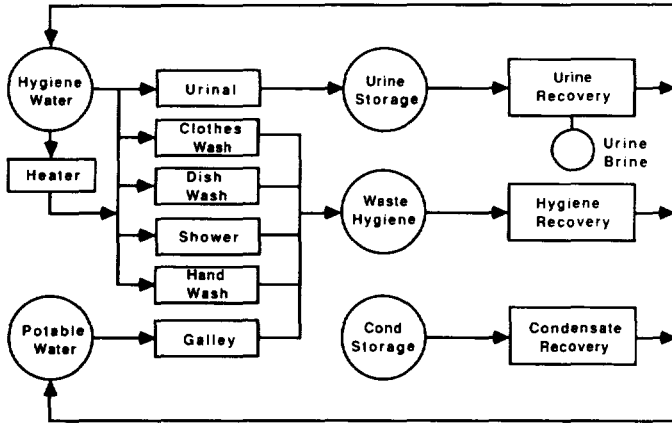

Fig. 3. Proposed space station ECLSS water reclamation system.

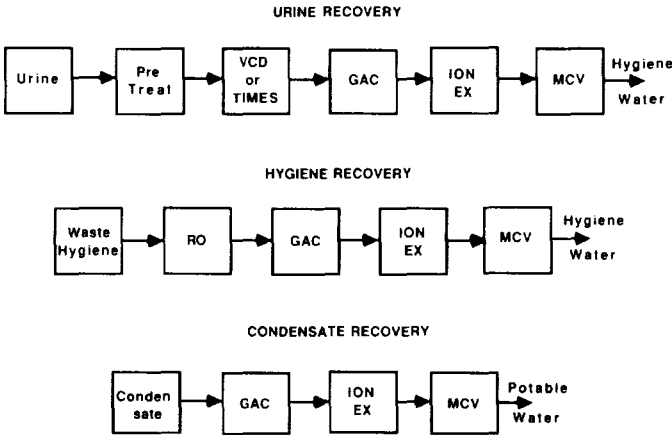

Fig. 4. Candidate subsystem configurations for ECLSS water reclamation.

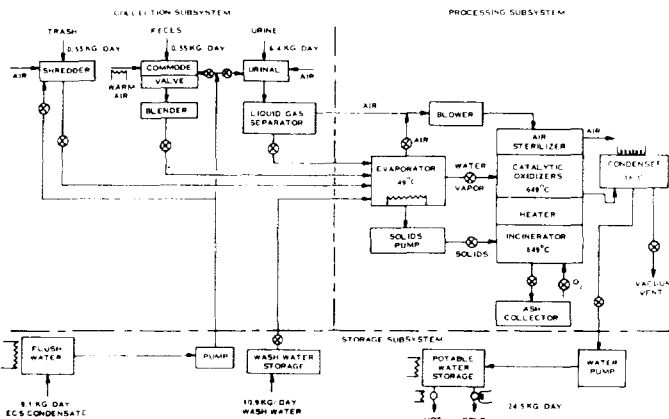

Fig. 5. Integrated waste and water management system (IWWMS).

Closed Ecological Life Support Systems

NASA has recently initiated a program aimed at developing a CELSS, which incorporates subsystems for food production and nutrient recovery. Figure 6 shows how these subsystems may be integrated into the IWWMS to develop a bioregenerative lunar base life support system. This system is based on the development of plant growth modules to produce food and to generate oxygen. An effort to develop such modules has been initiated at the Kennedy Space Center (*Prince et al.*, 1987). Initial work is being conducted with wheat and other crop plants. The use of algae has also been proposed (*Ward and Miller*, 1984; *Holtzapfle et al.*, 1988). This plant requires less volume and energy for growth than crop plants but contains less edible material. The goal of this program is to develop a breadboard CELSS to demonstrate the feasibility of the concept studies examining the chemical cycles involved. Such ground-based testing of the integrated system is necessary to certify the reliability of the equipment.

SUMMARY

The development of a water recycle system for use in the life support systems envisioned for a lunar base will require considerable research work. A review of previous work on aerospace water recycle systems indicates that more efficient physical and chemical processes are needed to reduce expendable and power requirements. Development work on biological processes that can be applied to microgravity and lunar environments also needs to be initiated. Biological processes are inherently more efficient than physical and chemical processes and may be used to minimize resupply and waste disposal requirements. Processes for recovering and recycling nutrients such as nitrogen, phosphorus, and sulfur also need to be developed to support plant growth units. The development of efficient water quality monitors to be used for process control and environmental monitoring also

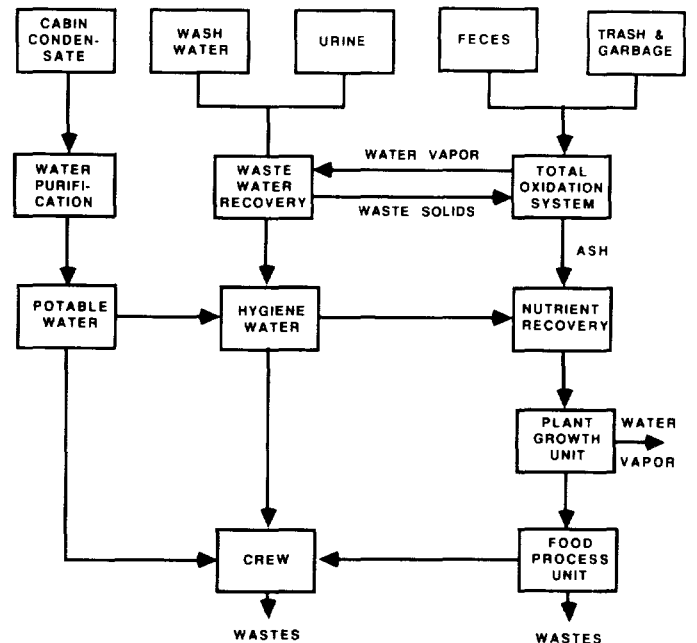

Fig. 6. Advanced lunar base water reclamation system.

needs to be initiated. Present methods require extensive instrumentation, highly trained personnel, and large space requirements that will not be available at a lunar base. The review also indicates very little integrated testing of advanced life support systems has been done. Although expensive, such testing is necessary to demonstrate the feasibility of such systems, examine interactions between the processes, and evaluate potential environmental health hazards.

REFERENCES

- Budininkas P. et al. (1986) Development of a water recovery subsystem based on vapor phase catalytic ammonia removal (VPCAR). *16th Intersociety Conference on Environmental Systems*, SAE Paper 860985. San Diego, California.
- Bull R. J. (1987) Toxicological aspects of water recycle and disinfection. *17th Intersociety Conference on Environmental Systems*, SAE Paper 871491. Seattle, Washington.
- Columbo G. V. and Sauer R. L. (1987) Review of water disinfection technology. *17th Intersociety Conference on Environmental Systems*, SAE Paper 871488. Seattle, Washington.
- Columbo G. V. et al. (1981) Advanced microbial check valve development. *11th Intersociety Conference on Environmental Systems*, ASME Paper 81-ENAS-45. San Francisco, California.
- Dehner G. F. and Price D. F. (1987) Thermoelectric integrated membrane evaporation subsystem testing. *17th Intersociety Conference on Environmental Systems*, SAE Paper 871446. Seattle, Washington.
- Duke M. B., Mendell W. W., and Roberts B. B. (1985) Strategies for a permanent lunar base. In *Lunar Bases and Space Activities of the 21st Century* (W. W. Mendell, ed.), pp. 57-68. Lunar and Planetary Institute, Houston.
- Hall J. B. (1973) *Domestic Wash-Water Reclamation Using an Aerospace Developed Water Recovery Subsystem*. NASA-TM-X-2896.
- Hall J. B. and Brewer D. B. (1986) Supercritical water oxidation: Concept analysis for evolutionary space station application. *16th Intersociety Conference on Environmental Systems*, SAE Paper 860993. San Diego, California.
- Holtzapfel M. T. et al. (1988) Analysis of an algae-based CELSS. In *Papers Presented to the Controlled Environmental Life Support Systems Research Conference*. Texas A&M University, College Station, Texas.
- Hong G. T. et al. (1987) Supercritical water oxidation: Treatment of human waste and system configuration tradeoff study. *17th Intersociety Conference on Environmental Systems*, SAE Paper 871444. Seattle, Washington.
- Janik D. S. et al. (1987) Medical effects of iodine disinfection products in spacecraft water. *17th Intersociety Conference on Environmental Systems*, SAE Paper 871490. Seattle, Washington.
- MacElroy R. D., Klein H. P., and Averner H. M. (1985) The evolution of CELSS for lunar bases. In *Lunar Bases and Space Activities of the 21st Century* (W. W. Mendell, ed.), pp. 623-633. Lunar and Planetary Institute, Houston.
- McCray S. B. et al. (1987) Development of a non-phase-change wastewater treatment subsystem. *17th Intersociety Conference on Environmental Systems*, SAE Paper 871514. Seattle, Washington.
- McDonnell Douglas Astronautics Company (1968) *60-Day Manned Test of a Regenerative Life Support System with Oxygen and Water Recovery*. NASA CR-98500.
- McDonnell Douglas Astronautics Company (1971) *Operational Ninety-Day Manned Test of a Regenerative Life Support System*. NASA CR-111881.
- McFeters G. A. and Pyle B. H. (1987) Consequences of bacterial resistance to disinfection by iodine in potable water. *17th Intersociety Conference on Environmental Systems*, SAE Paper 871489. Seattle, Washington.
- Meissner H. P. and Modell M. (1979) Recycling plant, human and animal wastes to plant nutrients in a closed ecological system. *9th Intersociety Conference on Environmental Systems*, ASME Paper 79-ENAS-29. San Francisco, California.
- Modar, Inc. (1984) *Evaluation of Organic Carbon Analyzers for Space Applications*. NASA Report NAS9-16675.
- Morasko G. et al. (1986) Air evaporation closed cycle water recovery technology—Advanced energy saving designs. *16th Intersociety Conference on Environmental Systems*, SAE Paper 860987. San Diego, California.
- Moses W. et al. (1987) Performance characterization of a waste/water recovery system. In *Papers Presented to the Controlled Environmental Life Support Systems Research Conference*. Texas A&M University, College Station, Texas.
- Murray R. W. and Sauer R. L. (1986) Integrated waste and water management system. *16th Intersociety Conference on Environmental Systems*, SAE Paper 860996. San Diego, California.
- Pierson D. L. and Brown H. D. (1987) Inflight microbial analysis technology. *17th Intersociety Conference on Environmental Systems*, SAE Paper 871493. Seattle, Washington.
- Prince R. P. et al. (1987) Design and performance of the KSC biomass production chamber. *17th Intersociety Conference on Environmental Systems*, SAE Paper 871437. Seattle, Washington.
- Putnam D. F. et al. (1986) Pre- and post-treatment techniques for spacecraft water recovery. *16th Intersociety Conference on Environmental Systems*, SAE Paper 860982. San Diego, California.
- Ray C. D. and Humphries W. R. (1986) Status of the space station environmental control and life support system design concept. *16th Intersociety Conference on Environmental Systems*, SAE Paper 860943. San Diego, California.
- Ray R. J. et al. (1986) A membrane-based subsystem for very high recoveries of spacecraft waste waters. *16th Intersociety Conference on Environmental Systems*, SAE Paper 860984. San Diego, California.
- Sauer R. L. (1985) Metabolic support for a lunar base. In *Lunar Bases and Space Activities of the 21st Century* (W. W. Mendell, ed.), pp. 647-651. Lunar and Planetary Institute, Houston.
- Slavin T. J. et al. (1986) CELSS waste management systems evaluation. *16th Intersociety Conference on Environmental Systems*, SAE Paper 860997. San Diego, California.
- Small J. W. (1987) Recent developments in water quality monitoring for space station reclaimed wastewaters. *17th Intersociety Conference on Environmental Systems*, SAE Paper 871547. Seattle, Washington.
- Spurlock J. and Modell M. (1979) Systems engineering overview for regenerative life-support systems applicable to space habitats. In *Space Resources and Space Settlements*. NASA SP-428.
- Spurlock J. et al. (1979) Research planning criteria for regenerative life-support systems applicable to space habitats. In *Space Resources and Space Settlements*. NASA SP-428.
- Verostko C. E. et al. (1986) Results on reuse of reclaimed shower water. *16th Intersociety Conference on Environmental Systems*, SAE Paper 860983. San Diego, California.
- Verostko C. E. et al. (1987) Test results of a shower water recovery system. *17th Intersociety Conference on Environmental Systems*, SAE Paper 871512. Seattle, Washington.
- Ward C. H. and Miller R. L. (1984) Algal bioregenerative systems for space life support. *The Physiologist*, 27, S-21.
- Willis C. E. and Bull R. J. (1987) *Space Station Water Quality Conference Report*. NASA JSC-32024.
- Willis C. E. and Schultz J. R. (1987) Spacecraft water system disinfection technology: Past, present and future needs. *17th Intersociety Conference on Environmental Systems*, SAE Paper 871487. Seattle, Washington.
- Zdankiewicz E. M. and Chu J. (1986) Phase change water recovery for space station—Parametric testing and analysis. *16th Intersociety Conference on Environmental Systems*, SAE Paper 860986. San Diego, California.
- Zlatkis A. (1986) *Organics in Water Contamination Analyzer*. NASA CR-179901, Ionics Research Inc.