

ADAPTION OF SPACE STATION TECHNOLOGY FOR LUNAR OPERATIONS

N93-17417

J. M. Garvey

Space Station Division
McDonnell Douglas Astronautics Company
Huntington Beach CA 92647

Space Station Freedom technology will have the potential for numerous applications in an early lunar base program. The benefits of utilizing station technology in such a fashion include reduced development and facility costs for lunar base systems, shorter schedules, and verification of such technology through space station experience. This paper presents an assessment of opportunities for using station technology in a lunar base program, particularly in the lander/ascent vehicles and surface modules.

INTRODUCTION

Current concepts for a lunar base program (Duke *et al.*, 1985; Hoffman and Niehoff, 1985; Woodcock, 1985; Ride, 1987; National Commission on Space, 1986) assume the presence of a low Earth orbit (LEO) space station as part of the overall mission infrastructure (Fig. 1). Such a station will function as a staging platform between Earth launch systems and lunarbound orbital transfer vehicles (OTVs), providing services such as vehicle assembly, checkout, and fuel storage.

Space Station *Freedom* (Fig. 2) represents the first step to creating such a LEO facility. This Phase I station will serve both as a testbed to develop the servicing capabilities mentioned above, and as a life sciences laboratory to gain better understanding of how life can function in space. Eventually, it could evolve into the staging platform for lunar missions.

An equally important aspect of Space Station *Freedom* is that the systems-level technologies that NASA is developing specifically for this program, such as data management, guidance and navigation, and communications, represent basic capabilities that in many cases can be applied directly to lunar base elements. This approach of using existing systems has been followed throughout the long history of lunar base planning (Louman, 1985; Johnson and Leonard, 1985). Now, with the advent of the design, development, test, and evaluation portion of the space station program, it is possible to assess such technology transfer at a finer level of detail. This paper reports on a preliminary internal study by McDonnell Douglas of such opportunities for the space station avionics.

BASELINE LUNAR BASE AND SUPPORTING ELEMENTS

This study assumes a Phase II lunar base, as defined by Duke *et al.* (1985) and Ride (1987; also known as the "Ride Report"). (Phase I in renewed lunar exploration would entail robotic exploration of the Moon during the 1990s, with the specific goal of finding a suitable site for the eventual lunar base. Phase II would then follow in the 2000 to 2005 timeframe and represents the initial return of people to the Moon. The associated surface facility would grow into the permanently occupied Phase III base,

with up to 30 inhabitants by 2010.) Although there are various versions of such a base, they share common requirements and features. Table 1 lists these items, as well as representative values.

Of all the possible elements, only the lander/ascent vehicles and lunar surface modules are considered here for potential applications. Although a lunar orbiting space station would help logistics and operations, it is not needed until the succeeding Phase III lunar base. The OTV is not included because it may be developed independently of the lunar base program, much like Space Station *Freedom* and the orbital maneuvering vehicle, and therefore is assumed to already exist by the time this program gets under way.

Lander and Ascent Vehicles

Several NASA-sponsored studies (Babb *et al.*, 1984; NASA, 1987a) defined a set of expendable/reusable, manned/cargo landers and ascent vehicles. Only the expendable elements are

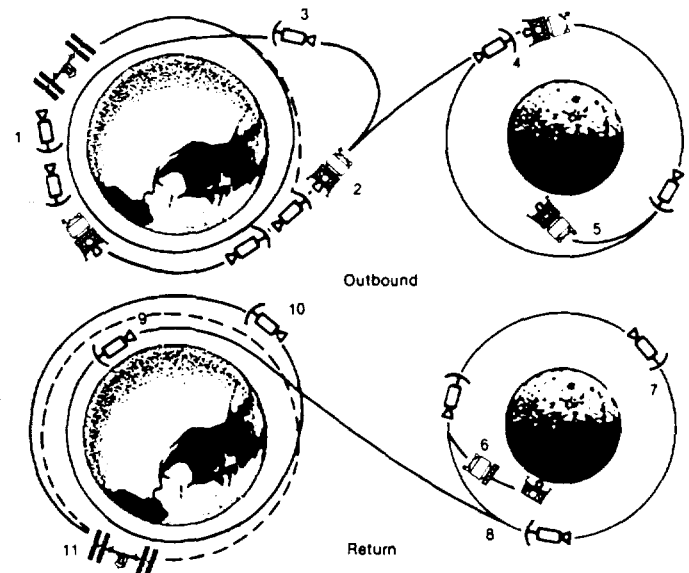

Fig. 1. Lunar base transportation infrastructure.

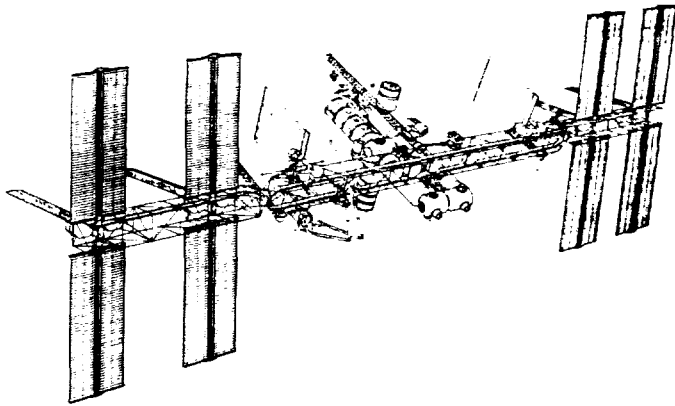

Fig. 2. Phase I Space Station Freedom.

TABLE 1. Mission parameters for Phase II lunar base.

Surface stay time	1 - 3 months
Crew size	3 - 5
Utilization of lunar resources	Soil for radiation shielding; otherwise, total resupply from Earth
ECLSS closure	Same as space station
Power	75 - 100 kW
Communications to Earth	Real time video (22 Mbps)
Location	Equatorial, nearside

considered here (Fig. 3) because they are the ones used during Phase II base operations. A large percentage of the avionics and software developed for these expendable landers can be adapted to the reusable versions when they are developed 10 years later.

Although the overall vehicle is expendable, it may prove feasible to recover high-value avionic components and reuse them either in new landers, or else somewhere in the growing lunar base.

Surface Modules

To achieve top-level commonality between the lunar base and Space Station Freedom, an initial lunar base design will incorporate space station-type modules. Hoffman and Niehoff (1985) propose one such initial operations configuration that consists of three main modules (habitation, laboratory, and service) and several interface nodes, as well as two rovers and a 100-kW nuclear reactor, while Duke et al. (1985) present a more generic module arrangement configuration. Figure 4 presents a lunar base model developed as part of our general studies in this area.

The interface elements are derived from the space station resource nodes, while the airlock is comparable to that on the station. A disposable logistics module is used for resupply.

As stated earlier, this review considers only the module systems, not the actual internal module configurations. The impact of the 1/6-g level on the microgravity-driven design of the station module interiors merits a separate study.

SPACE STATION TECHNOLOGY APPLICATIONS

Data Management System

The Space Station Freedom data management system (DMS) represents a major evolutionary step in onboard space processing capabilities. In contrast to previous space vehicles, which employ

a centralized architecture that is based on a main computer (plus backups), the station DMS functions will be distributed among over 20 stand-alone computers, termed standard data processors (SDPs), and several hundred embedded data processors (EDPs). This decentralized approach is intended to provide adequate flexibility to accommodate future station growth, technology improvements, and functional redundancy.

The SDPs and EDPs use the same 32-bit microprocessor (a space-qualified version of the Intel 80386) and present a family of processing capabilities that can fit a variety of user needs (Fig. 5). Other DMS hardware components include the 100 Mbps fiber optic core network, smart multiplexer/demultiplexers (MDMs), work stations, optical and tape mass storage units, and Mil-Std-1553 local data busses.

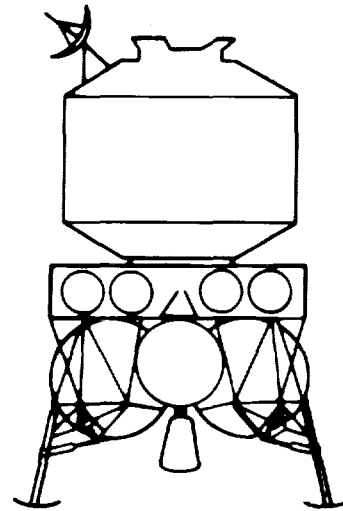

Fig. 3. Expendable lunar excursion module (from Babb et al., 1984). LLM total weight = 3.25 t. E-launcher propellant weight = 5.0 t; dry weight = 2.6 t; total weight = 7.6 t. E-lander (delivers 17.5 t to lunar surface) propellant weight = 13.6 t; dry weight = 3.8 t; total weight = 17.4 t.

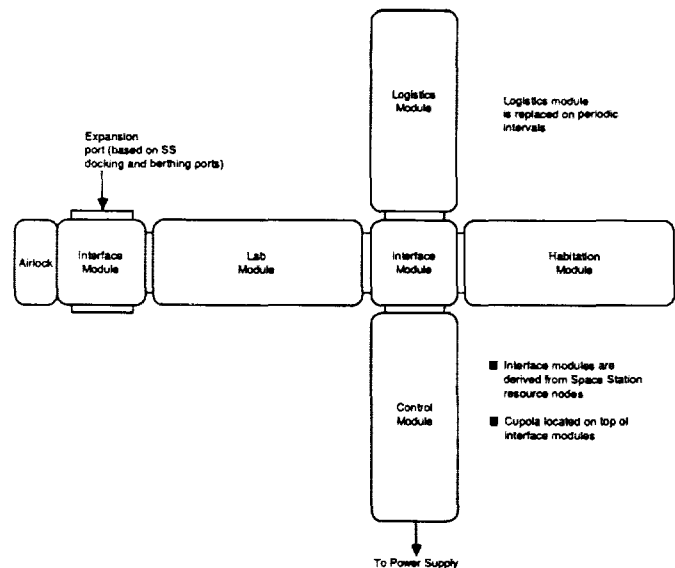

Fig. 4. Lunar base modules.

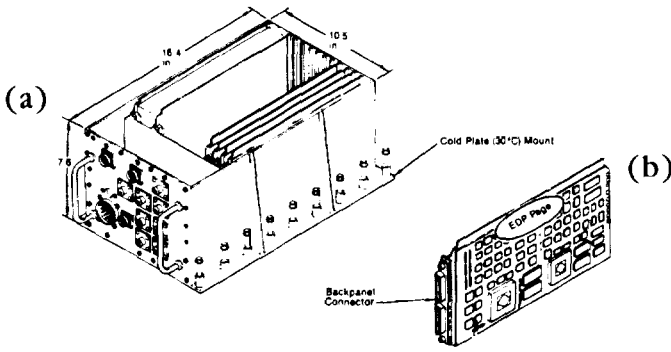

Fig. 5. DMS standard data processor: (a) Standard data processor (SDP): 4 Mips/growth to 8 Mips; 4 Mbytes/growth to 64 Mbytes per slot (1995); FDDI optical network interface; optional optical or wire local busses; radiation tolerant; VHSIC class parts. (b) Embedded data processor (EDP): 32-bit 80386 industry standard ISA for ground/onboard compatibility.

A single prime SDP, plus backup, using Mil-Std-1553 local busses to access MDMs and EDPs, should be able to provide all the data processing for a lander vehicle. For the surface base, the 100-Mbps core network can link the various elements together, while MDMs support monitoring and control functions. Both kinds of mass storage units could be called on to archive research data.

Software

NASA is undertaking two specific steps to ensure that space station software and the tools used to develop it will be transportable to future systems like the lunar base. First, all station software (with the exception of commercial off-the-shelf programs) shall be written in Ada, a structured language that is written for such transportability. The most "visible" software component will be the dedicated operations management system (OMS), consisting of a ground and on-orbit segment (OMGA and OMA, respectively), which will coordinate station operations and can serve as a model for subsequent lunar base software operating systems. Assuming that DMS hardware is used, the lunar base can also employ lower-level software, such as data display formats, encoding techniques, and built-in test. In general, the base will resemble Space Station *Freedom* in that it will generate a substantial amount of data that can undergo extensive on-site processing before transmission to Earth.

The station software will also include expert systems to provide highly autonomous operations, independent learning, and more efficient resource scheduling. The longer distance from Earth and limited manpower will make these features even more desirable at the lunar base, particularly during the interim periods when there is no crew.

The second relevant software issue is the software support environment (SSE) that NASA is creating to develop this station software (Fig. 6). It will consist of software production facilities (SPFs) at the various NASA centers and their associated contractors for software development, system development facilities (SDFs) for system-level integration of software and hardware, and a single multiple system integration facility (MSIF) where the top-level software integration will take place. All these facilities will incorporate flight-equivalent DMS hardware and operational software, with associated computer-based simulation programs to duplicate payloads and interfaces.

These various facilities will represent important national resources when Space Station *Freedom* is placed in orbit. Because they are functional and not physical equivalents of station systems, the MSIF, SPF, and SDF can easily be rearranged (generally by altering cable connections and rewriting simulation software) to new configurations such as a lander/ascent vehicle or a surface habitation module.

Communications and Tracking

For space-to-ground communications, Space Station *Freedom* will use TDRSS. Dedicated baseband processor units, Ku-Band transceivers, and a 2.75-m steerable antenna provide up to 300 Mbps throughput for real-time video and data transfer (Fig. 7).

The transmission segment of this system will be inappropriate for communications from the Moon to Earth, primarily because the TDRSS satellites are in geosynchronous orbit with their antennas pointing toward Earth. A direct microwave or laser link to Earth, or a dedicated relay satellite, would provide easier access (the microwave system would require larger antenna, ground receivers, and/or up-front amplifiers than those on the station to compensate for the greater distance).

Far better opportunities exist for applying Space Station *Freedom's* multiaccess proximity communication system, as well as internal audio/video and data collection equipment (TV cameras, pan tilt units, etc.). With respect to the proximity communication system, up to four users, such as EVA astronauts and approaching OTVs, can access the station through a second,

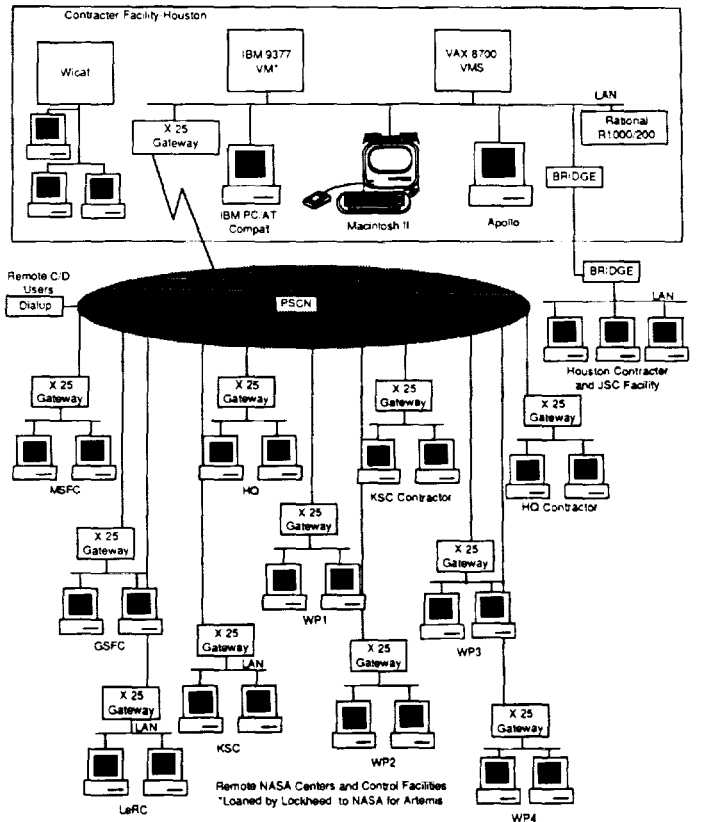

Fig. 6. Interim SSE system hardware and communications (derived from LMSC, 1987).

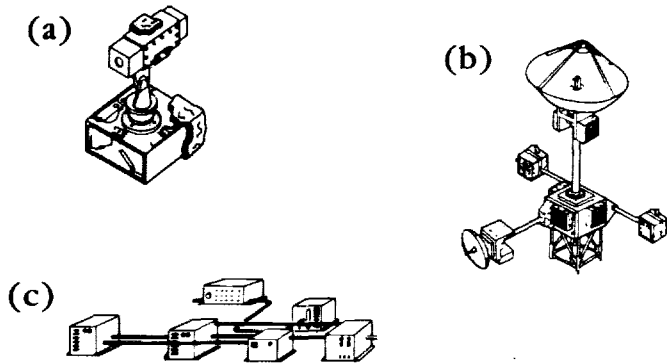

Fig. 7. Communications and tracking hardware: (a) video camera/pan tilt unit; (b) antenna boom, antenna-mounted equipment; (c) TDRSS high data rate frame multiplexer.

separate Ku-Band link that utilizes frequency division multiple access. This capability would serve well on the surface base for links to a lander and EVA work parties.

Guidance, Navigation, and Control

The space station Guidance, Navigation, and Control (GN&C) design incorporates ring laser gyros (RLGs) and star trackers to determine the attitude of a reference "Nav Base" to an accuracy of at least 0.01°. The companion coorbiting and polar orbiting platforms will also have Earth sensors for contingency purposes. Modified off-the-shelf GPS receivers will obtain data to determine position and velocity to a 3σ accuracy of 26 m and 0.1 m/sec, respectively.

Control is implemented through six 6760 N-m-s control momentum gyros (Fig. 8) and several sets of reaction control system thrusters that use gaseous hydrogen and oxygen for propellants.

This equipment is generally not useful for the surface modules, which are intended to retain fixed attitudes and positions on the lunar surface (some surveying tools may be needed for initial site studies and any intentional movements of modules). The main use of station attitude determination technology will be on the landers. The star trackers, in conjunction with lunar ephemeris data and/or Earth sensors, would generate periodic update references with respect to the Moon, while the RLGs would provide continuous information. If the Earth sensors are used, some software modifications will be required to address the different conditions at the Moon (no atmosphere, sharper terminator contrasts, etc.).

The control momentum gyros are probably too large and expensive for the landers, especially if the latter are expendable. The station's RCS technology could be called on if the lander has a H/O propulsion system.

Power

The total Space Station *Freedom* power facility consists of the electrical power system (EPS) and power management and distribution (PMAD) (NASA, 1987b). The EPS also performs the power storage task for the night portion of every orbit. Figure 9 depicts major components of these systems.

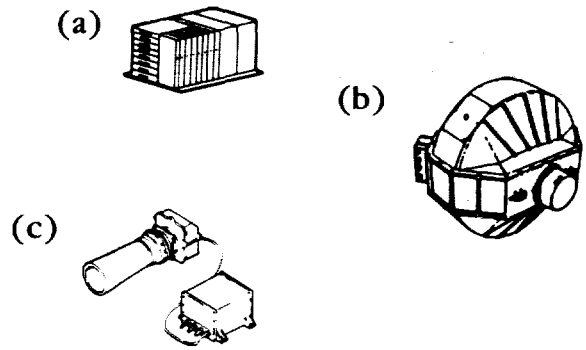

Fig. 8. Space station guidance, navigation, and control components: (a) Attitude determination system: Solid-state star tracker (ST) gives reliable, accurate performance; ISA provides reliable attitude data continuity when star tracker data unavailable; ISA/ST accuracy of 0.003°. (b) Control momentum gyro: Intell 80C86 processor; 1553B interface; double gimbal; 3500-ft-lb-sec momentum storage; dual electronics for each gimbal; 200-ft-lb torque; passive thermal cooling; BIT/BIT; minimum 10-year life. (c) Star tracker alignment ring innovation ensures boresight to navigation base alignment (0.0015°).

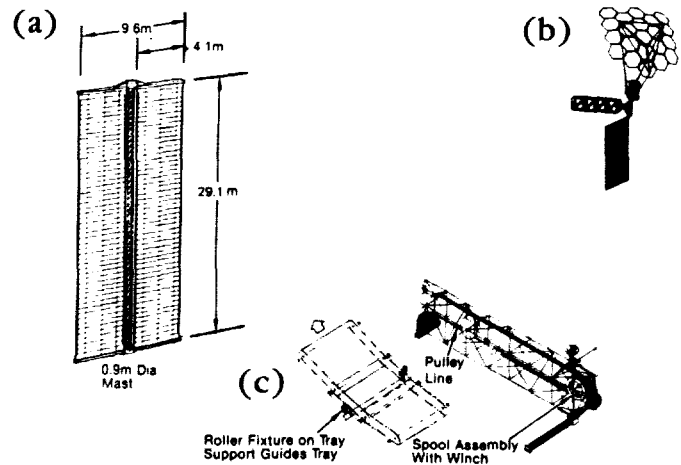

Fig. 9. Space station power components: (a) photovoltaic solar array (18.75 kW); (b) solar dynamic receiver (25 kW); (c) utility tray installation.

EPS will use four 9.6 × 29.1-m photovoltaic (PV) arrays during Phase I to generate 75 kW of power (end of life). Solar dynamic generators (SDs) are planned for Phase II of the station program and will add an additional 50 kW of power. The station will represent the first on-orbit application of this technology. Nickel-hydrogen batteries are used to store PV output, while molten eutectic salts undergo a phase change to maintain a set temperature difference in the SD receivers while the sun is eclipsed.

Like the SDs, the station PMAD entails major changes over current space vehicle power distribution systems (these changes are driven by the large size of the station). It will distribute 20 kHz ac at 440 V_{ac} along primary feed lines and 208 V_{ac} to users,

in contrast to the 28 V_{dc} used on most current spacecraft and 400 Hz ac on aircraft. This high frequency is expected to lead to lower transformer and switching equipment weights.

For the landers, only the Ni-H batteries may have some application. Otherwise, the rest of the power system can incorporate more traditional spacecraft components that operate at 28 V_{dc}.

The potential applications of Space Station *Freedom* power generation technology for the surface elements is less clear than for the previous technologies. Although the lunar base will have a grid architecture and power levels comparable to the station, the long duration of the lunar night will place drastically different requirements on the base's generation and storage systems. This has led many to consider nuclear power for the primary power source instead of solar energy (*Hoffman and Niehoff, 1985; Buden and Angelo, 1985; French, 1985*). However, as listed in Table 2, there are still a number of viable opportunities for supplemental solar power systems that could utilize the station elements.

The transferability of the 20-kHz PMAD elements is also uncertain. However, the utility tray design (Fig. 9c) can accommodate low-frequency cables and would provide easy deployment during base construction. Operating the lunar equivalent to a backhoe, lunar construction workers would dig a trench between a module and the power generation facility, unroll and connect the utility tray, and then cover it with soil for extra protection against micro-meteorites and rover vehicles.

TABLE 2. Applications for solar energy power generation systems.

Initial construction sorties—stay time <2 weeks
Short-term peak power surges
Drilling, heavy machinery
Energy-intensive material processing experiments
Autonomous mobile surface vehicles
Lunar base situated at the lunar poles

SUMMARY

The above discussion demonstrates that even at this early date, many opportunities can be identified for using Space Station *Freedom* technology in the design of lunar base systems and elements, with subsequent benefits of lower up-front costs, reduced technical and schedule risks, and program commonality. Table 3 summarizes such opportunities for the space station avionics systems. An additional benefit of such a study is awareness of what functions cannot be performed by space station technologies and therefore need further research and development.

Future efforts will include (1) a comparable assessment of other Space Station *Freedom* systems and elements (i.e., thermal, EVA, the mobile transporter, ECLSS, resource node, lab/hab module structure, manned systems); (2) continued refinement of the above analysis, particularly to assess cost implications; and (3) application of such a review to manned Mars missions.

REFERENCES

Babb G. R., Phillips P. G., and Stump W. R. (1984) *Impact of Lunar and Planetary Missions on the Space Station, Final Report*. Eagle Engineering Report No. 84-85D. Eagle Engineering, Houston.
 Buden D. and Angelo J. A. Jr. (1985) Nuclear energy—Key to lunar development. In *Lunar Bases and Space Activities of the 21st Century* (W. W. Mendell, ed.), pp. 85-98. Lunar and Planetary Institute, Houston.

TABLE 3. Applications of space station avionics technology in a lunar base.

	Lander/Ascent Vehicle	Surface Module
Data management system		
SDP	X	X
EDP	X	X
100 Mbps F/O network		X
Local data busses	X	X
MSU		X
Ring coupler		X
MDMs	X	X
Software		
MISF	X	X
SPF	X	X
SDF	X	X
SSE	X	X
OMA	X	X
OMGA	X	X
Built-in test	X	X
Expert systems	X	X
Other low-level code	X	X
Communications and tracking		
Multiple access Ku-band transceiver	X	X
Multiple access Ku-band antenna	X	X
Internal audio, video	X	X
EVA radio	X	X
Data collection equipment	X	X
Guidance, navigation, and control		
Star trackers	X	
ISA	X	
CMGs		
RCS	?	
Earth sensors	X	
Power		
Photovoltaic array		?
Solar dynamic receiver		?
Batteries	X	?
20 kHz PMAD		?
Utility tray		X

Duke M. B., Mendell W. W., and Roberts B. B. (1985) Strategies for a permanent lunar base. In *Lunar Bases and Space Activities of the 21st Century* (W. W. Mendell, ed.), pp. 57-68. Lunar and Planetary Institute, Houston.
 French J. R. (1985) Nuclear powerplants for lunar bases. In *Lunar Bases and Space Activities of the 21st Century* (W. W. Mendell, ed.), pp. 99-106. Lunar and Planetary Institute, Houston.
 Hoffman S. J. and Niehoff J. C. (1985) Preliminary design of a permanently manned lunar surface research base. In *Lunar Bases and Space Activities of the 21st Century* (W. W. Mendell, ed.), pp. 69-75. Lunar and Planetary Institute, Houston.
 Johnson S. W. and Leonard R. S. (1985) Evolution of concepts for lunar bases. In *Lunar Bases and Space Activities of the 21st Century* (W. W. Mendell, ed.), pp. 47-56. Lunar and Planetary Institute, Houston.
 LMSC (Lockheed Missiles & Space Corp.) (1987) *Interim SSE System User's Guide—Space Station Software Support Environment*. DRL Number 23, NASA Contract NAS9-117830. Houston, TX.
 Lowman P. D. (1985) Lunar bases: A post-Apollo evaluation. In *Lunar Bases and Space Activities of the 21st Century* (W. W. Mendell, ed.), pp. 35-46. Lunar and Planetary Institute, Houston.
 NASA (1987a) *Lunar Base Mission Accommodation at Space Station*. Status report presented to CSLI STAS meeting, NASA Langley, May 7, 1987.
 NASA (1987b) *Power System Description Document*. NASA Lewis Research Center, Cleveland.
 National Commission on Space (1986) *Pioneering the Space Frontier*. Bantam, New York. 211 pp.
 Ride S. (1987) *Leadership and America's Future in Space: A Report to the Administrator*. U.S. Govt. Printing Office, Washington, DC. 63 pp.
 Woodcock G. R. (1985) Mission and operations modes for lunar basing. In *Lunar Bases and Space Activities of the 21st Century* (W. W. Mendell, ed.), pp. 111-124. Lunar and Planetary Institute, Houston.